

CITY OF LAWRENCE
Water & Sewer Department
Water Division Rules & Regulations

The following Rules & Regulations are a part of the contract with every person who takes water from the City of Lawrence, and govern the relations between the Water & Sewer Department – Water Division (Lawrence Water Works) and its Customers and Contractor/Developers who install water systems.

All prior and existing Rules & Regulations pertaining to the Water Division are hereby amended and these Rules & Regulations substituted in place thereof except that where notice has already been given, or steps taken to enforce the payment of overdue water bills. In such cases, the Water & Sewer Department shall continue to have the right to proceed with such enforcement under the terms and conditions of the Rules & Regulations then in effect. Any modifications hereafter must be approved by a majority vote of the Lawrence City Council.

*These Rules & Regulations have been promulgated by the Lawrence Department of Public Works and accepted by the Lawrence City Council and will be in full force and effect as of **September 16, 2014**.*

THIS PAGE INTENTIONALLY LEFT BLANK

**City of Lawrence
Water & Sewer Department
Water Division
Rules & Regulations**

Table of Contents

Article	Contents	Page
I.	DEFINITIONS AND TERMS	1
II.	AUTHORITY & RIGHTS OF WATER & SEWER DEPARTMENT	2
	A. Rules & Regulations	2
	B. Rights of Access	2
	C. Consequences	3
III.	LIABILITY	3
IV.	WATER RATES AND BILLING	4
	A. Billing Process	4
	B. Abatement Process	5
V.	WATER METERS & RADIO READ SYSTEM	5
	A. General	5
	B. Residential Meters	6
	C. Industrial/Commercial Meters	7
	D. Remote Read Opt-Out Program	7
VI.	WATER SERVICE CONNECTIONS	7
	A. General	7
	B. Materials	8
	C. Installation	8
	D. Underground Irrigation Sprinkler Systems	9
VII.	MAINTENANCE	9
	A. Service Maintenance & Repairs	9
	B. Distribution Maintenance & Repairs	10
VIII.	WATER MAINS	10
	A. General	10
	B. Material	11
	C. Installation	11
IX.	FIRE PROTECTION	12
	A. Fire Lines	12
	B. Fire Hydrants	13
	C. Hydrant Use	13
X.	CROSS CONNECTION CONTROL ORDINANCE	13
	A. Purpose	13
	B. Authority	14

C.	Responsibility.....	14
D.	Definitions	14
E.	Administration	16
F.	Requirements.....	16
G.	Degree of Hazard.....	17
H.	Enforcement.....	17
I.	Approval Procedures	18
J.	Existing In-Use Backflow Prevention Devices.....	18
K.	Periodic Testing	18
L.	Records and Reports	19
M.	Strainers.....	19
N.	Lawn/Garden Irrigation	19

I. DEFINITIONS AND TERMS

1. **Building:** Any structure used for human occupancy, employment, and recreational or other purposes.
2. **Commercial/Industrial Meter:** Any meter 1.5" and larger used in residential and non-residential structures.
3. **Commercial/Industrial Unit:** A single, commercial or industrial unit, whether rented or owned by the business or occupant, which has independent ingress and egress or has common ingress and egress with other units within a building or structure, but with separate commercial or industrial facilities. Examples may include, but are not limited to; stores located in shopping centers or separate office or condominium units within a single building or structure.
4. **Customer:** Any person(s) who obtains water from a water pipe, fire hydrant or private yard hydrant supplied by a public water main (i.e., owner, tenant, occupant, lessee, firm, corporation, trust, developer, contractor etc.).
5. **Consumption:** The amount of water used, as measured by a meter or as estimated by the Water & Sewer Department in accordance with its billing procedures.
6. **Curb Stop:** The part of the water system, usually located at or near the owner's property line, where the City has complete access and control to shut off the water supply to the premises. Beyond this point, the water system belongs to and is the responsibility of the owner.
7. **Distribution System:** The network of pipes used for the delivery of water from the treatment facilities to the customer's system, generally terminated at the curb stop located at the property line.
8. **Hydrant:** A device connected to a public water main for the purpose of extinguishing fires or other authorized purposes.
9. **Master Meter:** A meter used for billing purposes serving a building or group of buildings.
10. **Meter:** An instrument for measuring the flow of water.
11. **Meter Pit:** An underground vault enclosing a meter.
12. **Owner:** A person who alone, or jointly or severally with others, has the legal title to any premises or has care, charge or control of any premises as agent, executor, administrator, trustee, lessee or guardian of the estate of the holder of legal title.
13. **Plumber:** A person licensed as a plumber by the Commonwealth of Massachusetts.
14. **Potable Water:** Water fit for human consumption in conformance with the regulations of the Massachusetts Department of Environmental Protection (MassDEP).
15. **Private Fire Protection/Fire Service:** Private water mains, hydrants and appurtenances installed for the purpose of fire protection at a particular premises.
16. **Public Fire Protection:** The public water mains, hydrants and appurtenances for the purpose of fire protection, installed in a public way, City-owned easement or private way open to public travel.
17. **Public Water Main:** The piping and associated valves, hydrants and appurtenances installed in a public way, City-owned easements, or private way open to public travel for the purpose of supplying water to one or more customers or for public fire protection.
18. **Residential Meter:** A meter 1" or less in size used to measure the flow of water to a residential or non-residential property.
19. **Service:** A water supply connection to a household of one or more people, stores, garages, laundries, manufacturing establishments, or any other residential or non-residential premises.

20. **Service Pipe/Connection:** The pipe running from the main in the street to include the curb stop and curb box at the property line, a shut off valve, meter, and meter connection inside the cellar wall.
21. **Shut Off:** The closing of a control valve to temporarily stop water service or to terminate water service.
22. **Terminate:** The cessation of water service, pursuant to the Water & Sewer Department's billing procedures or for violation of these regulations.
23. **City/Department:** The City of Lawrence Water & Sewer Department.
24. **Water Used:** Any water supplied by the Department or any other water system to a customer's water system after it has passed through the point of delivery and is no longer under the sanitary control of the water purveyor.

II. AUTHORITY & RIGHTS OF WATER & SEWER DEPARTMENT

A. Rules & Regulations

1. No representative of the Water & Sewer Department has the authority to change or modify said Rules & Regulations. The Water & Sewer Department will not recognize or be bound by any claimed change or modification hereof.
2. The Rules & Regulations of the Water & Sewer Department may be altered or amended at the discretion of the Water & Sewer Commissioner, with the approval of the City Council, and shall be included as part of the contract with every customer. All persons taking water from the Department shall be deemed to accede to and be bound thereby.
3. The Water & Sewer Commissioner reserves the right to change or amend these Rules & Regulations, and make additions thereto or exceptions therefrom, with the approval of the City Council, at any time without advance notice to the customer, and to establish and assess penalties for violations, including the right to suspend or terminate water service.
4. In the event that the Water & Sewer Commissioner position is vacant, the Department of Public Works Director reserves the right to designate a responsible party to exercise all authority granted herein.

B. Rights of Access

1. Agents or representatives of the Water & Sewer Department may enter the property of a customer at all reasonable times for the purpose of reading meters, inspecting or examining pipes, fixtures or attachments used by the customer.
2. Right of Access: Duly authorized representatives of the Water & Sewer Department may inspect the property or the facilities of any customers (including facilities under construction) to ascertain compliance with these regulations. Customers of premises where water service pipes or fire services are located shall allow properly identified Water & Sewer Department representatives ready access, at all reasonable times during normal business hours and at such other times as the Water & Sewer Department reasonably suspects that a violation of the regulations may be occurring, to such parts of the premises as would enable Water & Sewer Department personnel to inspect observe, measure, sample and test:
 - a. water use;
 - b. buildings;
 - c. water quality;
 - d. meters;
 - e. water service pipes;
 - f. fire services;
 - g. cross connections and backflow preventers; and

- h. other facilities that the Water & Sewer Department reasonably believes may be contributing to a violation of these Rules & Regulations.
 3. Right of Entry: Upon proper identification and at reasonable times during normal business hours and at such other times as the Water & Sewer Department reasonably suspects that a violation of these Rules & Regulations may be occurring, duly authorized representatives of the Water & Sewer Department shall be permitted to enter all private property through which the Water & Sewer Department holds an easement for the purpose of inspection, observation, measurement, sampling, testing, maintenance, repair or reconstruction of any portion of a public water main lying within said easement. All entry and subsequent work, if any, shall be done in full accordance with the terms of said easement.
 5. Security Clearance: Where a customer has security measures in force that would require clearance before entry to the premises, the customer shall make necessary arrangements to permit Water & Sewer Department personnel to enter without undue delay for the purpose of carrying out their specific responsibilities.
- C. Consequences
 1. Consequences of Denial of Entry or Access: Where a customer, after having received reasonable notice from the Water & Sewer Department refuses to permit properly identified Water & Sewer Department personnel to enter or have access to premises or facilities in accordance with the terms of this section, the Water & Sewer Department may forthwith give written notice of its intent, which may be up to and including the termination of water service to such customer, and/or a fee of no more than \$100.00 per billing period until access is granted.
 2. When the Water & Sewer Department determines that a) a violation of these regulations, or b) any damage to the public water mains, is threatened or has occurred, any one or more of the following actions may be taken:
 - a. The Water & Sewer Department may shut off water service as authorized elsewhere in these regulations.
 - b. The Water & Sewer Department may issue an order to cease and desist any such violation and may direct the violator(s) as follows:
 - 1) To comply with these Rules & Regulations and with the cease and desist order either forthwith or in accordance with a time schedule set forth by the Water & Sewer Department; or
 - 2) To take appropriate remedial preventive action in the event of a threatened violation.
 - 3) To take appropriate remedial action during or after a violation has occurred, at the expense of the customer.
 - c. The Water & Sewer Department may require the customer in question to submit a detailed schematic plan and time schedule showing the specific actions to be taken in order to prevent or correct a violation. The Water & Sewer Department may modify such schematic and time schedule, or require such other actions within such times, as the Water & Sewer Department deems appropriate.
 - d. The Water & Sewer Department may take direct enforcement action by filing suit in any court of competent jurisdiction pursuant to any applicable statute or regulation.

III. LIABILITY

- A. The City does not guarantee constant pressure nor uninterrupted service, nor does it assure the customer either a full volume of water or the required pressure per square inch necessary to effectively operate

hydraulic elevators, sprinkler systems or other appliances, the same being subject to all the variable conditions that may take place in the use of water from the City mains.

- B. No customer shall be entitled to damages, or to have payment refunded, for any interruption of supply occasioned either by accident to any portion of the works, or by shutting off for the purpose of additions or repairs to the works, or by the stoppage or shortage of supply due to causes beyond the control of the Water & Sewer Department, such as excessive drought, excessive use of and waste of water by other customers, or by leaks or defects in the pipes or appliances owned by him or other customers.
- C. The City will not be responsible for damages caused by dirty water resulting from the opening or closing of any gate for repairs or system maintenance, the use of any hydrant, or the breaking of any pipe.
- D. The City assumes no liability for conditions, which exist in customer's pipes and causes trouble coincident to or following the repairs of any main pipe, service pipe, meter or other appliance belonging to the Water & Sewer Department.
- E. The Water & Sewer Department reserves the right at any time without notice to shut off the water in the mains for purposes of making repairs, extension or for other necessary purposes. Customers having boilers or other appliances on their premises depending on the pressure in the pipes to keep them supplied with water are hereby cautioned against danger from these sources, and are required to provide, at their own expense, suitable safety appliances to protect themselves against such danger. In any event, it is expressly stipulated that the Department will not be liable for any damage resulting from water having been shut off, either through accident or necessity.

IV. WATER RATES AND BILLING

A. Billing Process

- 1. The Water & Sewer Commissioner shall establish rates and charges for the use of water and reserve the right to change the rates and charges as needed, with the approval of the City Council. Rates will be adjusted annually at the start of each fiscal year or as needed to maintain funds needed to operate the water system.
- 2. Water bills and service charges are issued on the first day of the month and are due on the last day of said month. Unpaid bills will be subject to 14% annual interest on any current balance due. Payment for all bills must be made by cash (under \$50.00), money order, or check. Unpaid bills, service charges and interest will become a lien on the real estate property tax bill.
- 3. Meter readings that cannot be obtained will result in an estimated reading for all accounts. This reading will be adjusted when an actual meter reading is obtained, but no monies shall be credited after the bill due date.
- 4. Any water account that requires an adjustment due to customer failure to allow accurate meter readings will be subject to a non-refundable manual reading fee, as specified in the Schedule of Fees and Service Charges (Attachment 1). Water & Sewer Department personnel must obtain a meter reading in order to adjust an estimated bill. Water bills will only be adjusted for the previous billing quarter.
- 5. Customers are responsible for the cost of all water supplied to their property, as indicated by their water meter, whether used, or wasted, intentional or unintentional, deliberate or by accident.
- 6. Payment for all final bills must be made by cash (under \$50.00), money order, certified or bank check, or attorney's IOLTA check drawn on a Massachusetts bank, in order to avoid the possibility of final payments becoming uncollectible due to insufficient funds. Both a visual and electronic readings must be obtained to generate a final bill.

B. Abatement Process

1. Requests for abatements of water bills or any portion thereof must be made in writing to the Water & Sewer Department and must include, at a minimum, the customer's name, property address, account number, and a detailed reason for the request.
2. Requests for abatements must be made prior to the due date of the water bill.
3. The Water & Sewer Commissioner will review abatement requests and make a decision based on the content of these Rules & Regulations.

V. WATER METERS & RADIO READ SYSTEM

A. General

1. The Water & Sewer Department will furnish, install and/or supervise installation, seal and maintain all commercial, industrial, and residential meters. The owner will provide a readily accessible, adequate and proper space or housing, which shall be heated to protect it from freezing. Cost of repair for abuse, neglect, tampering or vandalism shall be paid by the property owner. All metering equipment is the property of the City. All buildings with multiple tenants must have one master meter installed to record all water entering the building. All meters will be remote read as required by the Department.
2. All water services shall be metered and where there is more than one tenant or occupant on the premises, the meter rates, Rules & Regulations of the Water & Sewer Department shall apply to each. In all cases, the owner of the property supplied shall be held responsible for the water rates and all other charges, including that of all other customers in the building.
3. Unless written approval is granted by the Water & Sewer Commissioner, there will be one master meter for each service.
4. Meters and/or transmitters (MTUs) may not be removed except by or under the supervision of Water & Sewer Department personnel. Only Water & Sewer Department personnel may remove or replace the seals, which if broken, may indicate the meter has been tampered with. Any violation of this rule may result in fines and/or criminal charges. In all cases, any damage to the meter and/or reader or seals shall be repaired and the cost will be charged to the property owner.
5. The Water & Sewer Department is not responsible for leaks on the customer's property. The owner will be ultimately responsible for all water, which passes through a meter, whether caused by use, leaks or waste.
6. Upon customer request, meters shall be tested pursuant to Chapter 40, Section 39I of the Massachusetts General Laws. The accuracy of the meter on any property will be tested by the Water & Sewer Department, upon written request of the owner. Testing is performed in accordance to AWWA Standard C700.
 - a. If, on such test, the meter is found to register under or over two percent of water than actually passes through it, the meter will be replaced and the customer will incur no additional fees or expenses related to the testing of the meter. The water bill for the current period will be adjusted in accordance with the result of the test. If, however, the meter is found to be within the two percent tolerance, the customer will be charged with the expense of the examination and test, plus labor and administration costs associated with the testing of the meter.
 - b. If it appears that the customer was charged or has paid more than they should have, their account will be credited accordingly. If, however, it appears that the customer was charged or has paid for less water than they should have, they shall be charged with the additional amount.

7. There shall be a meter for every service and no customer shall attach or cause to be attached, a pipe to a metered service pipe or main for the purpose of furnishing water to an unmetered building or water using appliance.
8. All residential, commercial and industrial meters shall be AWWA and Water & Sewer Department approved and shall read in cubic feet with readout digits displayed in a single row and be able to be read by the Department's remote reading device. Customers are urged to contact the Water & Sewer Department prior to purchasing a water meter to verify compliance with these Rules & Regulations.
9. The customer should notify the Water & Sewer Department if the building is vacant and desires the water to be shut off, upon which time a meter reading must be obtained for billing purposes. When a service is turned off, the meter may be removed and returned to the Water & Sewer Department. The customer shall be responsible for a service shutoff fee, as specified in the Schedule of Fees and Service Charges (Attachment 1).
10. No meter bypasses will be allowed for industrial, commercial or residential premises without the written approval of the Water & Sewer Commissioner and in those cases, only with a meter installed on the bypass line. A compelling reason will be needed to consider a bypass.
11. The Water & Sewer Department, allowing reasonable notification to the property owner, shall have the right to access water meters and transmitters for the purpose of inspection and/or obtaining meter readings. Cancellation of appointments by the property owner shall be made in writing and delivered to the Water & Sewer Department at least 48 hours in advance. Failure to cancel an appointment or allow reasonable access to Water & Sewer Department personnel may result in additional service charges.
12. At no time shall customers tamper with the water meters. In the event that a water meter needs to be uninstalled for repair and maintenance projects, customers are responsible for contacting the Water & Sewer Department. Water & Sewer Department personnel and its designated contractors are the only representatives authorized to install/uninstall meters. Evidence of meter tampering will result in an estimated bill based on the highest bill received in the past three years, plus a fine of up to \$1,000 per inch diameter of the water meter. Exceptions to this rule include new meter installations or cases in which advanced written authorization has been granted by the Water & Sewer Commissioner.

B. Residential Meters

1. The Water & Sewer Department will test, remove, repair and/or replace residential meters as part of a regular maintenance program or as needed.
2. If a meter fails to register or is determined to be out of order, the Water & Sewer Department will notify the customer requesting that they make an appointment to have the meter replaced. The customer will be charged at the average daily consumption as shown by the meter when in order for the corresponding period of one year preceding. If past usage is undeterminable due to a lack of history (i.e., all estimated readings), a minimum of 700 cubic feet (per occupant) for that quarter will be charged.
3. If the customer does not respond to the notice and have the meter replaced, a non-adjustable bill of 10,000 cubic feet will be rendered every quarter thereafter until the meter is replaced.
4. The Water & Sewer Department will periodically read the inside meter to verify the accuracy of the remote recorder the department uses to obtain your meter reading. In the case of a discrepancy between the two readings, the inside meter reading will be considered accurate and the customer will be billed accordingly.

C. Industrial/Commercial Meters

1. Commercial and Industrial meters shall be furnished and installed by the owner but shall remain property of the Department and shall be of a size, type and located as approved by the Water & Sewer Commissioner based on the AWWA Manual Section M22 and M6 or as amended.
2. If an industrial/commercial meter appears to have gone out of order, the owner will be notified via certified mail. The owner will have 10 business days from receipt of the letter to coordinate with the Water & Sewer Department the repair or replacement of the meter. The Water & Sewer Department will make the necessary repair or replacement at its own expense for all situations in which the meter has no signs of abuse, neglect, tampering or vandalism.
3. Failure to respond to the first notice will result in a second notice informing the owner that if in 10 business days, the meter is not repaired or replaced water service to the building will be shut off. The billing will be based on the highest quarterly usage out of the last four billing cycles.
4. The Water & Sewer Commissioner can require that a large commercial or industrial meter be tested if there is reason to believe that said meter is not registering water accurately. These tests will be done at the customer's expense.
5. The Water & Sewer Commissioner, at his/ her discretion, may direct the owner of a property in which a large meter is installed, to have the same analyzed to determine whether the meter size is appropriate.

D. Remote Read Opt-Out Program

1. A customer may, at his/her discretion, opt out of the remote read program. In order to do so, the Department must be notified in writing of their intent to opt out. In the letter, the customer shall provide, at a minimum, their name, address, and account number. All fees and expenses associated with a manual meter reading will be incurred by the customer.
2. The Opt-Out Program is for the Meter Transmitting Unit (MTU) only; the installation/replacement of water meters is mandated by the Department and cannot be opted out of.
3. The Opt-Out Program is applicable to current property owners only. Current property owners are those listed on City tax records at the time of the enactment of these Rules & Regulations. Upon the sale or transfer of a property subject to these Rules & Regulations, a MTU must be installed as part of the remote read program.

VI. WATER SERVICE CONNECTIONS

A. General

1. Service connections shall be made under the direction of the Water & Sewer Commissioner or his/her designee. No dwelling, house, or other building or structure shall be connected by any service pipe without such authorization nor shall any person otherwise use water supplied by the City except with the formal consent of the Water & Sewer Commissioner. Any person violating this section is subject to prosecution under the provisions of Chapter 165, Section 11 of the Massachusetts General Laws.
2. Prior to any work being performed the owner or his agent will be required to:
 - a. Fill out the Water Service Application at The Water & Sewer Billing office.
 - b. Pay the service connection fee, if applicable, as specified in the Schedule of Fees and Service Charges (Attachment 1).
 - c. Submit a plan showing the location of the water service, any existing or proposed sewage/septage systems, utilities or other appurtenances that may affect the water service.
3. All service connections shall be installed by the Water & Sewer Department personnel or a licensed and bonded contractor. Water service connections to be installed will require an advanced 72 hour

notice. Inspection of water service connections will be subject to rates as specified in the Schedule of Fees and Service Charges (Attachment 1). All connections shall be inspected by Water & Sewer Department personnel prior to backfilling. All unauthorized connections are subject to immediate water shutoff by the Water & Sewer Department.

4. The Water & Sewer Department may take a maximum of ten (10) days to review building permit applications, and ten (10) days to review occupancy permits to ensure all costs are paid and inspection work is complete.
5. The Water & Sewer Department will not allow activation of any new service unless all charges due the Water & Sewer Department have been paid and all inspection work is completed.
6. For services to be terminated permanently, it is required that the property owner physically disconnect the pipe at the water main. The owner is responsible for all costs incurred in the process. Service termination must be done by Water & Sewer Department personnel or a licensed and bonded contractor. Inspection of water service disconnections will be subject to rates as specified in the Schedule of Fees and Service Charges (Attachment 1). All disconnections shall be inspected by Water & Sewer Department personnel prior to backfilling.
7. The Water & Sewer Department, in no way, assumes any responsibility for frozen service lines. Necessary thawing of lines and/or repairs are the responsibility of the property owner.

B. Materials

1. All service lines shall not be less than 3/4" and shall be type k copper tubing, or 3/4" PE (150-PSI min. meeting ANSI/AWWA C901-96 Standard) plastic tubing as approved by the Water & Sewer Commissioner. The service from the water main up to the curb stop will be type k copper and a minimum of 30 feet out from the foundation will be type k copper.
2. All corporations, curb stops, unions or fittings shall be Mueller, Ford, Red-Head or other such fittings as approved by the AWWA and ultimately the Water & Sewer Commissioner. No Hayes fittings (compression type) will be allowed. All curb stops shall open left.
3. Curb boxes shall be the adjustable Buffalo type – six foot (6') bury.
4. Water services that are a distance of 150 feet or more from the water main to the foundation will require a 1" tap, or as directed by the Water & Sewer Commissioner. The service from the water main up to the curb box will be type k copper and a minimum of 30 feet out from the foundation will be type k copper. Plastic pipe, PE, (see Section VI.B.1) can be installed in-between but must be 150 PSI minimum and will require detectable metallic underground tape.

C. Installation

1. All services shall be installed perpendicular to the dwelling.
2. All service lines shall be installed with a minimum of four and half feet (4 ½') and a maximum of six feet (6') of cover to finished grade.
3. Service pipes shall be backfilled with sand or other suitable fine material to twelve inches (12") over the pipe. The remaining trench shall be backfilled with suitable material with no stone or boulder over one cubic foot (1 cf.) in size.
4. No water taps will be made to any water main smaller than 6 inches (6") in diameter, unless approved by the Water & Sewer Commissioner.
5. Taps at the main shall be direct and saddles will not be allowed unless approved by the Water & Sewer Commissioner.
6. All service valves shall be installed in the OFF position. Water & Sewer Department personnel only

shall turn a service on or off.

7. A meter and valve of approved type will be installed on each service. Larger size service pipes or meters will be allowed only upon special permission. All meters shall be installed in locations accessible for reading and maintenance and shall not be installed under the foyer or enclosed entrance to dwellings with split entry designs.
8. It is the intent of the Water & Sewer Department to restrict installation of water services through property owned by parties other than the proposed. Residential services through easements to serve a maximum of two (2) single family homes may be allowed if the Water & Sewer Commissioner determines that extending a water main in the public way is not practical or beneficial to the City. Each individual service must be shown on the definitive subdivision plan and must be approved by the Water & Sewer Commissioner. The Water & Sewer Department will not be responsible for any repairs on pipes and other appurtenances within the easements.
9. No other source of water; i.e., wells tanks, etc., shall be connected to any pipe supplying potable water from the City system without the written approval of the Water & Sewer Commissioner and the Massachusetts Department of Environmental Protection (MassDEP) (Refer to Massachusetts General Laws Chapter 111, Section 160A) (310 CMR 22.22) (see Section X).

D. Underground Irrigation Sprinkler Systems

1. The installation of underground irrigation sprinkler systems will be allowed but the following criteria must be met:
 - a. The sprinkler connection to the water service will be after the meter.
 - b. An approved backflow device will be installed for water safety purposes.
2. Customers are reminded that if a water emergency or water shortage were to occur or be declared, the use of water for irrigation purposes could be banned temporarily or permanently if conditions warrant it.

VII. MAINTENANCE

A. Service Maintenance & Repairs

1. The Water & Sewer Department, in no way, assumes any responsibility for reseeding of lawns or replacement of shrubs or trees or other landscaping damaged in the performance of any repair work.
2. Prior to the City making any repairs on a service, a Water & Sewer Department representative will examine the service and provide for the customer a description of the recommended repairs and estimated cost.
3. The City will not make any repairs on a water service past the meter.
4. The City will absorb the cost of repairs on the service between the water main and the curb stop unless it is at the request of the owner for the purpose of upgrading the service.
5. The owner will be responsible for the cost of labor and material incurred between the curb stop and the meter, including the curb stop, as specified in the Schedule of Fees and Service Charges (Attachment 1). The City will charge for materials based on the Water & Sewer Department's most current purchase price.
6. The owner may hire a licensed and bonded contractor to perform any repairs on the service. It will be necessary that Water & Sewer Department personnel inspect the work and will be subject to the inspection fee, as specified in the Schedule of Fees and Service Charges (Attachment 1).
7. If a water service is found to be leaking, the City reserves the right to shut the service off without prior notice. The City will attempt to notify the owner of the leak and the shutdown. The City will not be held

responsible for any damage to pipes, hot water heaters, boilers or any other appliance that may have been caused by the service being shut off. The water will remain turned off until the leak is repaired in accordance with all requirements set forth in these Rules & Regulations.

8. When a customer is notified of a non-critical leak on their property, they will have 48 hours to make necessary repairs. If repairs are not made within 48 hours, the water service will be repaired by the Water & Sewer Department and charged accordingly to the property owner. If the owner is unwilling to complete repairs, the Department may terminate water service until the necessary repairs are made.
9. The Water & Sewer Department is not responsible for making repairs to any water service at an industrial or commercial building. The Water & Sewer Department does however, have the authority to deem a leak an emergency and order or take immediate action.
10. Pipes not owned by the City shall be kept in good repair by the property owner.

B. Distribution Maintenance & Repairs

1. The Water & Sewer Department reserves the right at any time without notice to shut off the water mains for making repairs, extensions or for other necessary purposes. Customers having boilers or other appliances on their premises depending on the pressure in the pipes to keep them supplied with water are hereby cautioned against danger from these sources, and are required to provide, at their own expense, suitable safety appliances to protect themselves against such danger. In any event, it is expressly stipulated that the Department will not be liable for any damage resulting from water having been shut off, either through accident or necessity.
2. Each spring, the Water & Sewer Department will perform a water main flushing program, which aids in removing sediments that collect in the pipeline, resulting in improved water quality. All gates and hydrants will be checked for proper operation. This program may cause some discoloration and change in water quality. Public notification will be given by way of local newspaper and City website. The Department cannot be held liable for any damage to plumbing or household items.

VIII. WATER MAINS

A. General

1. The Water & Sewer Commissioner shall determine main sizes and valve locations when construction plans are submitted. In determining main size, the present and potential future water supply requirements of the area will be taken into consideration. The minimum water main size shall be eight inches (8") in diameter except as approved by the Water & Sewer Commissioner.
2. Before installing any water main, approval must be obtained from the Water & Sewer Commissioner.
3. The Water & Sewer Commissioner in conjunction with the Fire Chief shall determine hydrant locations. The minimum spacing between hydrants shall be 500 feet (500').
4. Unless otherwise specified in writing and signed by the Water & Sewer Commissioner, all water mains, hydrants, valves, and associated appurtenances located within public ways, City owned easements and private ways open to public travel within the City are owned by the City.
5. The Water & Sewer Commissioner shall control the use of all public water mains in the City. No person shall, without prior written authorization from the Water & Sewer Commissioner, uncover, make any connection with or opening into, alter or disturb a water main or service.
6. When installing a new water main to provide water to a parcel, it is required that the main be extended to the furthest property line, where an inline gate and a fire hydrant will be installed and/or the extended portion of the main will be tapped into an existing adjacent water main for looping purposes, all to be determined at the discretion of the Water & Sewer Commissioner. A water service lateral, from the

- main to the curb stop, shall be provided for any and all parcels along the alignment of the extension that are not presently on City water.
7. Water main installation shall conform to the Manufacturer's recommendations, the MassDEP Regulations, the latest revision of AWWA C600, and the City's construction specifications.
 8. All water mains being installed shall be under the full time inspection of a person designated by the Water & Sewer Commissioner. All costs associated with inspection shall be the responsibility of the Customer.
 9. Water mains to be installed in a proposed development that will be owned, operated and maintained by the City shall only be constructed in public streets or proposed public streets.
 10. Water mains may be located in easements only when it is determined by the Water & Sewer Commissioner to be in the best interest of the public safety, of improved water quality and of minimized maintenance activity. When water mains are located in easements, the results will be properly laid out and recorded at the Registry of Deeds, by the owner of the property and/or reflected in any or all subsequent deeds affecting the easement. Water mains located in easements shall be constructed in accordance with construction standards set forth by the Water & Sewer Department Rules & Regulations. Easements shall be a minimum of twenty feet (20') wide.
 11. No installation of new water services or mains will be permitted in the roadway during the winter season when road opening permits are not being issued by the Department of Public Works, except in such cases as the Water & Sewer Commissioner deems emergencies.

B. Material

1. Water mains shall be double cement-lined, seal-coated ductile iron pipe with push-on type joints. Pipe shall be thickness class 52 and shall conform to the latest revision of AWWA C151.
2. Valves shall conform to the latest revision of AWWA C515 for gate valves. All valves shall open RIGHT. A slide-type adjustable type box shall be used with each valve. All valves shall be mechanical joint.
3. Hydrants shall be American Darling B-62-B-5, as manufactured by AMERICAN Flow Control of Birmingham, Alabama; or Mueller Super Centurion 250, as manufactured by Mueller Water Products, Inc., of Atlanta, Georgia, and shall open left. The color shall be red with silver caps and bonnet for high service areas, and yellow with silver caps and bonnet for low service areas.
4. Fittings shall be ductile iron and conform to the latest revision of AWWA C153. All fittings shall be mechanical joint.
5. Retainer glands shall be installed at all mechanical joints. Retainer glands shall be rated at 350 psi for 4-inch (4") through 24-inch (24") diameters, and 250 psi for glands larger than 24-inch (24").

C. Installation

1. All newly installed water mains shall be hydrostatically pressure tested for strength and leakage in the presence of Water & Sewer Department personnel. An independent water testing company other than the contractor who installed said water main shall conduct hydrostatic testing in accordance with the latest revision of AWWA C600, Section 5.
2. The main shall be flushed prior to chlorinating and then shall be chlorinated in an approved manner by the Contractor. The Contractor shall be responsible for neutralizing the chlorine residual of the disposed water. Neutralization chemical tablets and dosages listed in Appendix C of AWWA C651 (latest revision) are recommended. After chlorinating, the contractor shall take bacteria samples in the presence of Water & Sewer Department personnel for analysis at a MassDEP certified laboratory. The disinfection procedure shall be considered satisfactory only if the results of all tests confirm the absence

- of coliform bacteria in all samples and HPC bacteria less than 500 colony-forming units per milliliter (cfu/mL). If the initial disinfection procedure fails to produce satisfactory results, the water mains shall be flushed and re-sampled as described above. If the re-sampling fails to produce satisfactory results, the disinfection procedure shall be repeated.
3. All pipes shall be installed in trenches with not less than five feet (5') cover from finish grade to top of pipe unless approved by the Water & Sewer Commissioner. All pipe installed with less than 5'-0" of cover (where approved) shall be insulated with a minimum 2-inch, 40 pound density Styrofoam material.
 4. Thrust blocks shall be installed at all tees, bends, caps and plugs. Concrete used for thrust restraint shall be 3,000 psi (minimum) and shall be sized in accordance with the thrust block schedule provided in Attachment 2.
 5. Where main is installed through ledge, a minimum of twelve inches (12") clearance on all sides of pipe must be maintained. Filling around pipe shall be suitable gravel or sand properly tamped. When laying pipe on soft or swampy ground, unsuitable material shall be removed and replaced with suitable material and approved by the Department.
 6. Backfilling shall be carefully done and sand or gravel shall be placed and properly tamped to at least twelve inches (12") over the main before general backfilling is started. No boulders or rocks larger than one cubic foot (1 cf.) in size shall be placed in the trench. Where excavated material is not suitable for replacing in the opinion of the Construction Inspector, it shall be removed from the job and clean gravel substituted.
 7. All hydrants shall be backed with concrete or other suitable material to a solid unbroken trench wall. All hydrant isolation gates shall be mechanically restrained to the tee as approved by the Water & Sewer Commissioner. All hydrants shall be properly based so they may have proper drainage. Where soil conditions do not allow proper drainage, there shall be excavated a space of at least one cubic yard (1 cy). This excavation shall be filled with crushed stone. The hydrant base shall rest upon a flat stone or concrete block for support. Where groundwater is present at base of hydrant, hydrant drain plugs shall be permanently plugged.
 8. Water main gate valves shall be located at all intersections and at intermediate points not exceeding one thousand feet (1,000 ft.) in length or as directed by the Water & Sewer Commissioner.
 9. Arrangements for temporary water to be used in construction and/or site work must be made with the Water & Sewer Commissioner.

IX. FIRE PROTECTION

A. Fire Lines

1. The entire fire line extending from the public water main to the premises and including the control valve at the main shall be owned and maintained by the property owner.
2. Private fire protection lines shall be constructed in accordance with the Water & Sewer Department specifications and latest versions of the Massachusetts plumbing code, City Fire Prevention Code and National Fire Code.
3. No fire service line shall be laid in the same trench with any other public or private utilities, except a water service pipe. Nor shall any fire service be installed within ten feet (10') horizontally of a sewer pipe. Any connection of fire service line to a public main shall be made in a public way at ninety degrees (90°) to the City water main.
4. The owner or the owner's agent shall be responsible, at its expense, for installing the fire pipe and appurtenances, tapping and making connection to the public water main, and cutting and capping any

water service pipe to be abandoned. The owner or his agent shall arrange with at least 72 hours advance notice for any inspection by the Water & Sewer Department.

5. All fire lines are subject to a one-time connection fee, Fire lines are also subject to an annual charge based on the size of the fire line. Such annual charges shall not include or be used for maintenance or repair costs to the fire service pipe. Maintenance and repair costs are to be borne by the owner of the premises.

B. Fire Hydrants

1. Unless the Water & Sewer Commissioner expressly determines otherwise, with respect to specific locations, all hydrants located in public ways, City-owned easements or private ways open to public travel shall be owned and maintained by the Water & Sewer Department.
2. Hydrants shall be placed at locations designated by the Water & Sewer Commissioner, in conjunction with the Lawrence Fire Chief, to facilitate public fire protection. As a condition of new or extended water service, the Water & Sewer Department may require an owner, at his expense, to install a hydrant, if the Water & Sewer Commissioner or Fire Chief determines that such new or extended water service creates additional fire protection requirements or water quality concerns.
3. All persons are forbidden to shut off or turn on water from any pipe, hydrant or other fixture intended for fire protection without the approval of the Water & Sewer Commissioner, except firefighters for the purpose of extinguishing a fire or practice sessions during reasonable periods. Persons found making unauthorized use of fire hydrants shall be subject to a fine of \$1,000.00 and/or M.G.L Chapter 165, Section 11.
4. No object, material, debris or structure of any kind shall be placed on or around any fire hydrant or gate box connected with the water system so as to prevent easy access to the hydrant or gate box at all times.

C. Hydrant Use

1. Hydrant use requires 72 hour notice to the Water & Sewer Department.
2. Only Water & Sewer Department personnel will perform operation of hydrants or valves unless the Water & Sewer Commissioner grants written authorization.
3. Fire flow tests shall be conducted at such times designated by the Water & Sewer Commissioner to minimize the impact of the test on the water system, ice on the roadways and the customers of the Water & Sewer Department. A copy of any fire flow test results must be forwarded to the Water & Sewer Commissioner.
4. Any person found to be operating a fire hydrant without the authorization of the Water & Sewer Commissioner will be subject to a fine of \$1,000.00 and/or M.G.L Chapter 165, Section 11.
5. Any person causing damage to a fire hydrant will be held responsible for all costs related to the repair or replacement of said hydrant.
6. Hydrant use will be allowed at the discretion of the Water & Sewer Commissioner. Typically hydrant use will be denied from November 1 to April 15.

X. CROSS CONNECTION CONTROL ORDINANCE

A. Purpose

1. To protect the public potable water supply from the possibility of contamination or pollution by isolating such contaminants or pollutants, which could backflow or back-siphon into the public water system.
2. To promote the elimination or control of existing cross connections, actual or potential, between its

customers' in-plant potable water system and non-potable systems.

3. To provide for the maintenance of a continuing program of cross connection control which will effectively prevent the contamination or pollution of all potable water systems by cross connection.

B. Authority

1. As provided in the Federal Safe Drinking Water Act of 1974, (Public Law 93-523), and the Commonwealth of Massachusetts Drinking Water Regulations, 310 CMR 22.22, the water purveyor has the primary responsibility for preventing water from unapproved sources or any other substances from entering the public potable water system.
2. As provided in Chapter 13.16 of the Lawrence Code of Ordinances.

C. Responsibility

1. The Water & Sewer Commissioner shall be responsible for the protection of the public potable water distribution system from contamination or pollution due to the backflow or back-siphonage of contaminants or pollutants. If, as a result of a survey of the premises, the Water & Sewer Commissioner or his/her designee determines that an approved backflow prevention device is required at the City's water service connection or as inplant protection on any customer's premises, the Water & Sewer Commissioner, or his/her designee, shall issue a cross connection violation form to said customer to install approved backflow prevention devices. The customer shall, within a time frame determined by the Water & Sewer Commissioner, install such approved device or devices at his own expense, and failure or refusal or inability on the part of the customer to install said device or devices within the specified time frame shall constitute a ground for discontinuing water service to the premises until such device or devices have been properly installed.

D. Definitions

1. **Air Gap Separation:** The method of preventing backflow through the use of an unobstructed vertical distance through the free atmosphere between the lowest opening from any pipe or faucet supplying water to a tank, plumbing fixture, or other device and the flood level rim of the receptacle. This unobstructed vertical distance shall be two times the diameter of the line supplying water, but never less than one inch.
2. **Approved:** Accepted by the Reviewing Authority as meeting an applicable specification stated or cited in this regulation or as suitable for the proposed use.
3. **Approved Backflow Prevention Device or Devices:** A method to prevent backflow approved by the Department for use in Massachusetts.
4. **Atmospheric Vacuum Breaker:** An approved backflow device used to prevent back siphonage, which is not designed for use under static line pressure.
5. **Auxiliary Water Supply:** Any water supply of unknown or questionable quality on or available to the premises other than the supplier's approved public potable water supply.
6. **Back Pressure:** Pressure created by mechanical means or other means which causes water or other liquids or substances to flow or move in a direction opposite to that which is intended.
7. **Back Siphonage:** A form of backflow due to reduced or subatmospheric pressure within a water system.
8. **Backflow:** The flow of water or other liquids, mixtures or substances into the distribution pipes of a potable water supply from any source other than the intended source.
9. **Backflow Preventer with Intermediate Atmospheric Vent:** A device having two independently operating check valves separated by an intermediate chamber with a means for automatically venting it

- to the atmosphere, in which the check valves are force loaded to a normally closed position and the venting means is force loaded to a normal open position.
10. **Barometric Loop:** A loop of pipe rising at least 35 feet (35'), at its topmost point, above the highest fixture it supplies.
 11. **Certified Backflow Surveyor/Tester:** An individual who holds a valid Massachusetts Backflow Prevention Device Testers Certificate, or a Surveyors Certificate or a combination Tester/Surveyor Certificate issued by the Department.
 12. **Water & Sewer Commissioner:** The City of Lawrence Water & Sewer Commissioner or owner or operator of a public water supply system.
 13. **Contaminant:** Any physical, chemical, biological or radiological substance or matter in water.
 14. **Cross Connection:** Any actual or potential connection between a distribution pipe of potable water from a public water system and any waste pipe, soil pipe, sewer, drain, or other unapproved water source.
 15. **Cross Connection Violation Form:** A violation form designated by the Water & Sewer Commissioner, which is sent to the owner by the water supplier with copies sent to the Department, plumbing inspectors and Board of Health delineating cross connection violations found on the owner's premises and a procedure for corrective action.
 16. **MassDEP:** The Massachusetts Department of Environmental Protection.
 17. **Design Data Sheet:** Shall mean a form, designated by the Water & Sewer Commissioner, which is submitted to the Water & Sewer Commissioner or his/her designee, along with plans for each installation of a reduced pressure backflow preventer, double check valve assembly, or for each change to any such device already installed, describing and showing the details of the specific installation.
 18. **Double Check Valve Assembly:** A backflow prevention device, which incorporates an assembly of check valves, with shut-off valves at each end and appurtenances for testing.
 19. **In-Plant Protection:** The location of approved backflow prevention devices in a manner, which provides simultaneous protection of the public water system and the potable water system within the premises.
 20. **Inspection:** Shall mean the physical examination and testing of an installed backflow prevention device to verify that the backflow prevention device is functioning properly.
 21. **Non-Potable Water:** Water that is not safe for human consumption or which is of questionable quality.
 22. **Owner:** Any person maintaining a cross connection installation or owning or occupying premises on which cross connections can or do exist.
 23. **Permit:** A document issued by the Water & Sewer Department, which allows a cross connection installation.
 24. **Person:** Any individual, corporation, company, association, trust, partnership, the Commonwealth, a municipality, district, or other subdivision or instrumentality of the United States.
 25. **Pressure Vacuum Breaker:** An approved backflow prevention device designed to prevent only back siphonage and which is designed for use under static line pressure and which has necessary appurtenances for testing.
 26. **Reduced Pressure Backflow Preventer:** An approved backflow prevention device incorporating (1) two or more check valves, (2) an automatically operating differential relief valve located between the two checks, (3) two shut-off valves, and (4) necessary appurtenances for testing.

27. **Residential Dual Check:** An assembly of two spring loaded, independently operating check valves without tightly closing shut-off valves and test cocks. Generally employed immediately downstream of the water meter to act as a containment device.
 28. **Reviewing Authority:** The Lawrence Water & Sewer Commissioner, his/her designee, or the local plumbing inspector, authorized by M.G.L. c. 142 and licensed by the Board of State Examiners of Plumbers and Gas Fitters, are responsible for the review and approval of the installation of an approved backflow prevention device.
- E. Administration
1. The Water & Sewer Commissioner will operate an active cross connection control program, to include the keeping of necessary records, which fulfills the requirements of the MassDEP's Cross Connection Regulations and is approved by the MassDEP.
 2. The owner shall allow his property to be inspected for possible cross connections and shall follow the provision of the Water & Sewer Department's program and the MassDEP regulations.
- F. Requirements
1. Water & Sewer Department
 - a. On new installations, the Water & Sewer Commissioner or his/her designee will provide on-site evaluation and/or inspection of plans in order to determine the type of backflow preventer, if any, that will be required, and notify the owner of plan approval requirements by the appropriate reviewing authority.
 - b. For premises existing prior to the start of this program, the Water & Sewer Commissioner or his/her designee will perform surveys of the premises and reviews of as-built plans and issue a cross connection violation form to the owner detailing any corrective action required, the method of achieving the correction, and the time allowed for the correction to be made. The time period allowed shall depend upon the degree of hazard involved.
 - c. The Water & Sewer Department will not allow any cross connection to remain unless it is protected by an approved backflow preventer for which a permit has been issued and which will be regularly tested to ensure satisfactory operation.
 - d. If the Water & Sewer Commissioner or his/her designee determines at any time that a serious threat to the public health exists, the water service will be terminated immediately.
 - e. The Water & Sewer Department shall have on its staff, or shall have a delegated representative, who is a backflow prevention device tester/surveyor certified by the Commonwealth of Massachusetts.
 2. Owner
 - a. The owner shall be responsible for the elimination or protection of all cross connections on his premises.
 - b. The owner shall be responsible for applying for and obtaining all necessary approvals and permits for the maintenance of cross connections and installation of backflow prevention devices, and applying annually for the renewal of each permit.
 - c. The owner shall have any device that fails an inspection or test repaired or replaced by a licensed plumber within fourteen days.
 - d. The owner shall inform the Water & Sewer Department of any proposed or modified cross connection and also any existing cross connections of which the owner is aware but has not been found by the City's cross connection representative.

- e. The owner shall not install a by-pass around any backflow preventer unless there is a backflow preventer of the same type on the bypass. Owners who cannot shut down operation for testing of the device(s) must supply additional devices necessary to allow testing to take place.
- f. The owner shall install backflow preventers in a manner approved by the Department and by the Water & Sewer Commissioner.
- g. The owner shall install only reduced pressure backflow preventers and double check valve assemblies approved by the MassDEP.
- h. Any owner of industrial, commercial, or institutional premises having a private well or other private water source must have a permit if the well or source is cross connected to the City's system. Permission to cross connect may be denied by the Water & Sewer Commissioner. The owner may be required to install a backflow preventer at the service entrance if a private water source is maintained even if it is not cross connected to the City's system.
- i. The owner of any residential premises having a private well or other private water source will not be allowed a physical cross connection with the public water supply system.
- j. The owner shall be responsible for the payment of all fees for permits, backflow prevention device testing, retesting in the case that the device fails to operate correctly, and second re-inspections for non-compliance with the Water & Sewer Department or MassDEP requirements.

G. Degree of Hazard

1. The Water & Sewer Department recognizes the threat to the public water system arising from cross connections. As such, the Water & Sewer Commissioner, whereas he/she is responsible for the quality of the public water supply, may require a containment device on the water service entrance to any customer who, as a result of unprotected cross connections, could contaminate the public water supply system.
2. Any existing backflow preventer shall be allowed to continue in service unless the degree of hazard is such as to supersede the effectiveness of the present backflow preventer or results in an unreasonable risk to the public health.
3. Where the degree of hazard has increased, as in the case of a residential installation converting to a business establishment, any existing backflow preventer must be upgraded to a reduced pressure backflow preventer, or a reduced pressure backflow preventer must be installed in the event that no backflow device was present.
4. Any fire system, where an unapproved water source can be pumped into it by the fire department, or fire pump system, will require the installation of a reduced pressure backflow preventer.

H. Enforcement

1. The Water & Sewer Department shall not allow a cross connection to exist with the public water supply system unless it is considered necessary and all appropriate approvals and permits have been issued.
2. Unprotected cross connections are in direct violation of the Drinking Water Regulations of Massachusetts General Laws, Chapter 111, Section 160A prescribe a fine of \$25,000.00 per day and/or a year in jail for each willful violation of a Drinking Water Regulation promulgated by the MassDEP.
3. Unprotected cross connections may be subject to additional fines prescribed by the Water & Sewer Department. Additionally, failure to comply with the regulations set forth in this section may result in termination of water service.

I. Approval Procedures

1. As per Massachusetts General Laws, Chapter 111, Section 160A and Section 22 of the Drinking Water Regulations of Massachusetts (310 CMR 22.22), all installations of reduced pressure backflow preventers and double check valve assemblies in cross connection installations must be issued a permit from the Water & Sewer Commissioner or his/her designee.
2. In order to be issued a permit, a plan showing each installation must be submitted to the Water & Sewer Commissioner for review and approval. This plan must include the following:
 - a. A completed design data sheet.
 - b. A schematic showing incoming water lines, the separation of domestic and process water, the type and model number of the device to be used, and all clearances involved in the installation.
3. After review and approval of plans and the subsequent installation of backflow prevention devices, an initial inspection must be arranged to verify the correct installation of the device and to conduct a test of the device to ensure proper operation. The permit to maintain a cross connection will be issued by the Water & Sewer Commissioner or his/her designee after such initial inspection has been conducted by the Water & Sewer Department.

J. Existing In-Use Backflow Prevention Devices

1. Any existing backflow preventer shall be allowed by the Water & Sewer Department to continue in service unless the degree of hazard is such as to supersede the effectiveness of the present backflow preventer or result in an unreasonable risk to the public health.
2. Where the degree of hazard has increased, as in the case of a residential installation converting to a business establishment, any existing backflow preventer must be upgraded to a reduced pressure backflow preventer, or a reduced pressure backflow preventer must be installed in the event that no backflow device was present.

K. Periodic Testing

1. Reduced pressure backflow preventer assemblies shall be tested and inspected at least semi-annually and double check valve assembly devices shall be tested at least annually by the Water & Sewer Department or its agent. The City reserves the right to perform additional tests at any time.
2. Additional periodic testing may be performed by the Water & Sewer Department certified tester or his/her delegated representative, who shall be a certified tester.
3. The testing shall be conducted during the Water & Sewer Department's regular business hours. Exceptions to this may be allowed when made at the request of the owner, and may require additional charges to cover the increased costs to the City.
4. Any backflow preventer which fails during a periodic test must be repaired or replaced by a licensed plumber. When repairs are necessary, upon completion of the repair, the device will be retested at the owner's expense to ensure proper operation. High hazard situations will not be allowed to continue unprotected if the backflow preventer fails the test and cannot be repaired immediately. In other situations, a compliance date of not more than fourteen days after the test date will be established. The owner is responsible for spare parts, repair tools, or a replacement device. Parallel installation of two devices is an effective means of the owner ensuring that uninterrupted water service remains during testing or repair of devices and is strongly recommended when the owner desires such continuity.
5. Backflow prevention devices will be tested more frequently than specified above in "A" in cases where there is a history of test failures and the Water & Sewer Commissioner feels that due to the degree of hazard involved, additional testing is warranted. Cost of the additional tests will be the responsibility of the owner.

L. Records and Reports

1. Records: The Water & Sewer Department will initiate and maintain the following:
 - a. Master files on customer cross connection tests and/or inspections.
 - b. Master files on approved cross connection installations.
 - c. Copies of lists and summaries supplied to the MassDEP.
2. Reports: The Water & Sewer Department will submit the following to the MassDEP:
 - a. Initial listing of high hazard cross connections.
 - b. Initial listing of low hazard cross connections.
 - c. Annual update lists of Items 1 and 2 above.
 - d. Annual summary of cross connection inspections and surveys.

M. Strainers

1. The Water & Sewer Department strongly recommends that all new and retrofit installations of reduced pressure backflow preventers and double check valve assemblies include the installation of strainers located immediately upstream of the backflow device. The installation of strainers will preclude the fouling of backflow devices due to both foreseen and unforeseen circumstances occurring to the water supply system such as water main repairs, water main breaks, fires, periodic cleaning and flushing of mains, etc. These occurrences may "stir up" debris within the water main that will cause fouling of backflow devices installed without the benefit of strainers.

N. Lawn/Garden Irrigation

1. All new or existing municipal, commercial, industrial and institutional property owners are required to have in place, a reduced pressure backflow device or a double check valve assembly device on their irrigation system. The type of device will be decided by the Water & Sewer Commissioner or his/her designee upon submission and approval of a Design Data Sheet and plumbing plan.
2. In regard to existing pressure vacuum breakers, these existing devices must be installed at a minimum of two feet above the highest sprinkler head, as determined by the Water & Sewer Commissioner or his/her designee or be replaced by a reduced pressure backflow device or a double check valve assembly.
3. These existing pressure vacuum breaker devices will be inspected by the Water & Sewer Commissioner or his/her designee, and may continue to be utilized unless it fails in testing, at which time it must be replaced by a reduced pressure backflow device or a double check valve assembly, as determined by the Water & Sewer Commissioner or his/her designee.

THIS PAGE INTENTIONALLY LEFT BLANK



CITY OF LAWRENCE

WATER & SEWER DEPARTMENT

City Hall • 200 Common Street • Lawrence, MA 01840

Tel: (978) 620-3110 • www.cityoflawrence.com

BRIAN PEÑA
COMMISSIONER

ATTACHMENT 1: SCHEDULE OF FEES AND SERVICE CHARGES

Water Meter Testing	Cost and labor
Replacement of Water Meter	Materials* and labor
Manual Read of Water Meter	\$100.00 per reading
Final Reading Fee (AMR)	\$40.00 per reading
Final Reading Fee (Manual)	\$100.00 per reading
Installation/Connection of Water Service	Materials* and labor
Repair or Replacement of Water Service	Materials* and labor
Water/Sewer Service Connection Fee	\$200.00 per inch diameter per pipe
Service Shutoff/Turn-on Fee	\$50.00 per instance
Cross Connection Survey	\$25.00 per survey
Design Data Sheet Approval/Inspection Fee	\$35.00 per device
Backflow Preventer Inspection/Testing Fee	\$75.00 per commercial device \$25.00 per residential device
Fire Service Connection Fee	\$200.00 per inch diameter per pipe
Annual Fire Service Fee	\$75.00 per inch diameter
Hydrant Permit Fee	\$40.00 per day or metered usage
Meter or Backflow Preventer Deposit (refundable)	\$1,500.00 per device
Copies of Bills	\$1.00 per account
Demand Fee	\$20.00 per instance

CURRENT RATES

Water Rate	\$3.10 per hundred cubic feet (Minimum charge of \$21.70 applies)
Sewer Rate	\$3.35 per hundred cubic feet
Labor Charge	\$40.00 per hour
Labor Charge (After Hours)	\$60.00 per hour
Labor Charge (Sundays & Holidays)	\$80.00 per hour
Excavator Charge	\$100.00 per hour
10-Wheeler Charge	\$85.00 per hour
Back Hoe Charge	\$90.00 per hour
Bobcat Charge	\$50.00 per hour
Compressor & Attachments Charge	\$50.00 per day
Pumps Charge	\$35.00 per day

* A 10% administration fee will be added to all material costs. Customers will be charged for parts based on the Water & Sewer Department's most current purchase price. Material and labor estimates will be provided by the Water & Sewer Department prior to the commencement of any work.

THIS PAGE INTENTIONALLY LEFT BLANK

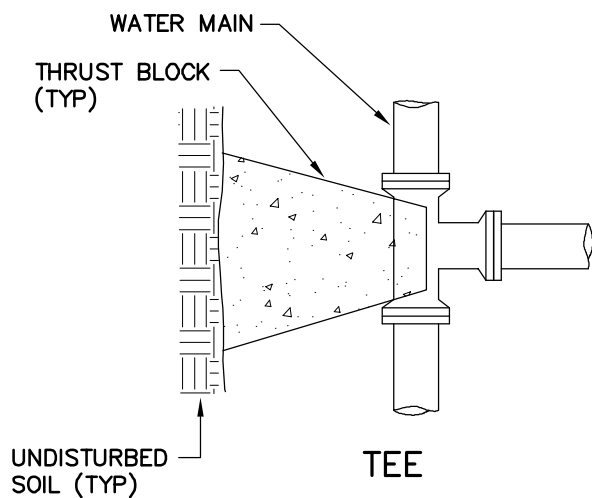

TEE

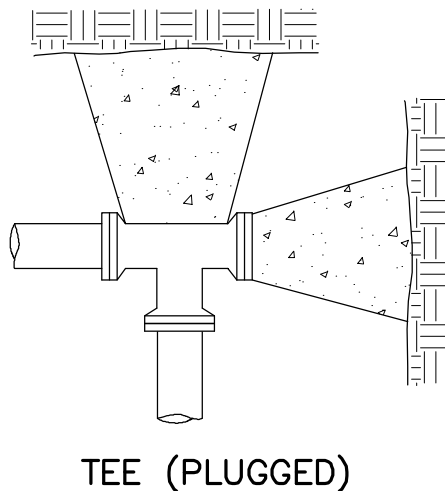

TEE (PLUGGED)

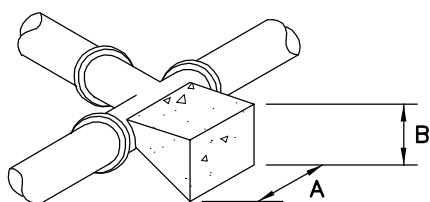

TEE

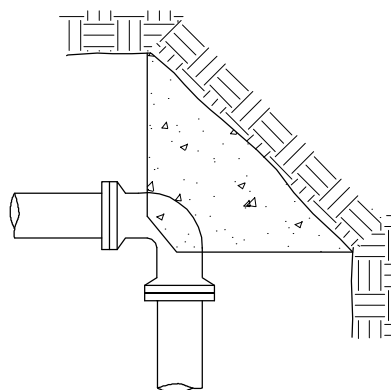

BEND

TABLE 1: 4" THRU 10" FITTINGS				
SOIL TYPE	TEES		BENDS	
	A	B	A	B
SOFT CLAY	48"	24"	48"	24"
SAND	24"	24"	24"	24"
GRAVEL	24"	18"	24"	18"

TABLE 2: 12" THRU 16" FITTINGS				
SOIL TYPE	TEES		BENDS	
	A	B	A	B
SOFT CLAY	60"	36"	72"	36"
SAND	36"	30"	48"	30"
GRAVEL	30"	24"	40"	24"

NOTES:

1. CONCRETE FOR ALL THRUST BLOCKS TO BE MINIMUM 3,000 PSI., 28 DAY STRENGTH, TYPE I CEMENT, 3/4" STONE.
2. WHERE POSSIBLE, CONSTRUCT THRUST BLOCKS AGAINST UNDISTURBED SOIL. WHERE NOT POSSIBLE, PLACE FILL BETWEEN THE THRUST BLOCK AND THE UNDISTURBED SOIL COMPACTED TO 90% STANDARD PROCTOR DENSITY.
3. WRAP FITTINGS WITH POLYETHYLENE PRIOR TO CONSTRUCTING THRUST BLOCKS. NO JOINTS SHALL BE COVERED WITH CONCRETE.
4. THRUST BLOCK DIMENSIONS ARE BASED ON A MAXIMUM WATER MAIN PRESSURE OF 150 PSI. FOR WATER MAIN PRESSURE EXCEEDING 150 PSI., THRUST BLOCK DETAILS MUST BE SUBMITTED FOR WATER DEPARTMENT APPROVAL.

ATTACHMENT 2: TYPICAL THRUST BLOCK DETAIL